



**NEMO**  
**IN/OUT**

---

*2016*

**NEMO**

*Made in Italy*

# INDEX

4	MAIS PLUS QUE CELA JE NE PEUX PAS <i>Rudy Ricciotti</i>
10	KEPLER <i>Arihiro Miyake</i>
14	PROJECTEUR 365 <i>Le Corbusier</i>
18	3TUBES <i>Charles Kalpakian</i>
20	BORNE BÉTON <i>Le Corbusier</i>
26	LINESCAPES SYSTEM <i>Nemo Studio</i>
32	OLYMPIA <i>Doriana and Massimiliano Fuksas</i>
34	TRU PENDANT <i>Roberto Paoli</i>
38	PARLIAMENT <i>Le Corbusier</i>
40	SPIGOLO XS <i>Studiocharlie</i>
42	ELLISSE <i>Federico Palazzari</i>
46	CROWN WALL <i>Jehs+Laub</i>

# MAIS PLUS QUE CELA JE NE PEUX PAS

*Rudy Ricciotti*



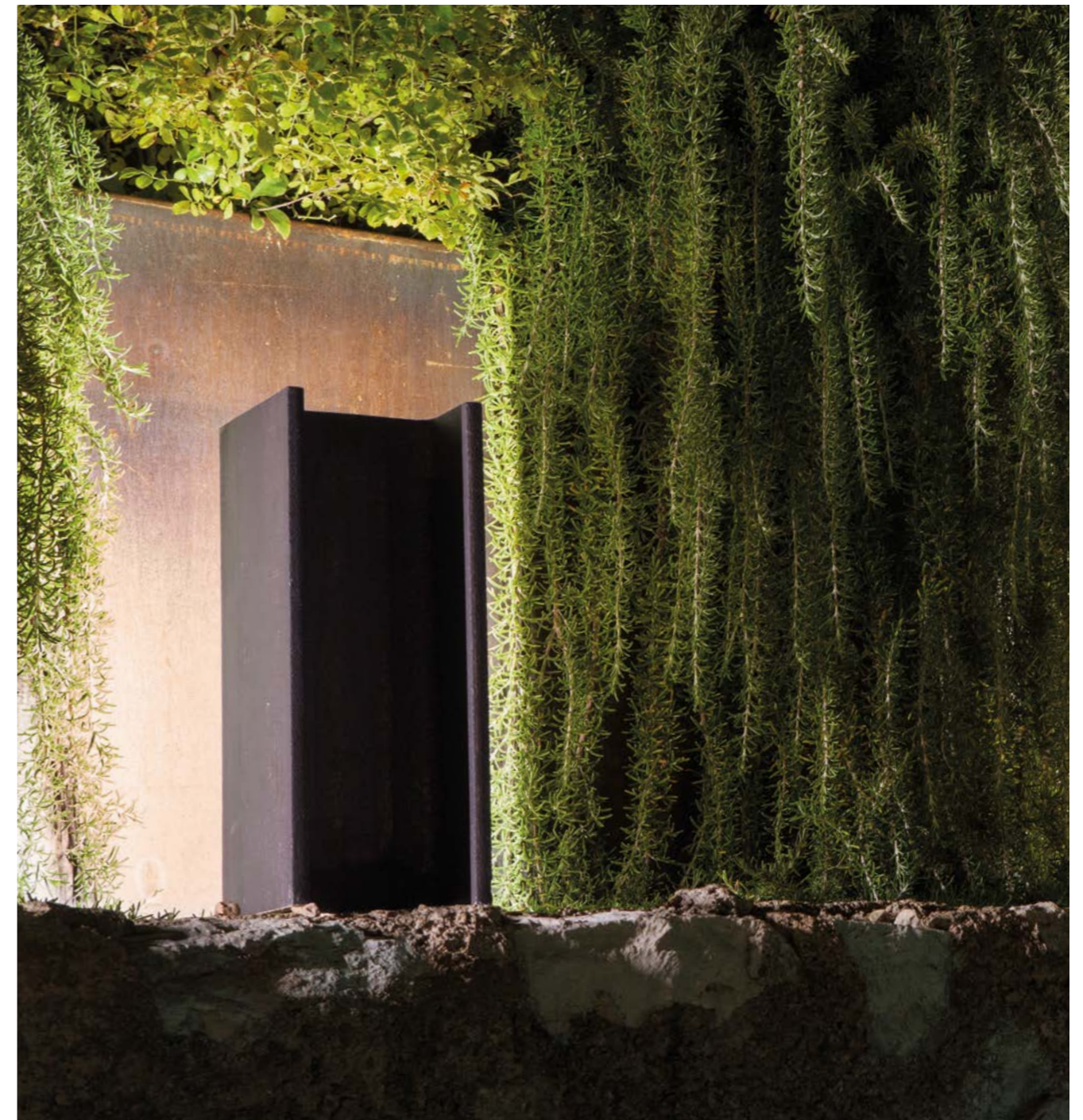

Indoor and outdoor floor and table lamp, raw material, treated with protection outdoor paint, for a warm and widespread lighting.

Lampada da interno ed esterno, da terra e tavolo, in metallo grezzo, trattata con vernice di protezione per esterni, per un'illuminazione calda diffusa.

Pour intérieur et extérieur, lampadaire et table, en métal brut, traité avec vernis de protection pour extérieurs, pour un éclairage chaud et diffus.

Steh- und Tischleuchte für innen und außen aus rohem Metall, Schutzlack für den Einsatz im Freien, für eine diffuse warme Beleuchtung.

*"Mais plus que cela je ne peux pas"  
outdoor version.*

#### OUTDOOR IP65

Linear LED | direct/indirect | 10W | 1000lm |  
typ cri 83 | CCT 2700K | dimmable, TRIAC | 220V |  
note cable lenght 3m, cable supplied with molded  
IP44 plug

● RIC LMM 2E *structure raw metal*

#### INDOOR

Linear LED | direct/indirect | 10W | 1000lm |  
typ cri 83 | CCT 2700K | dimmable, TRIAC | 220V |  
note cable lenght 2,7m, dimmer on cable

● RIC LMM 21 *structure raw metal*



*"Mais plus que cela je ne peux pas"  
indoor version.*

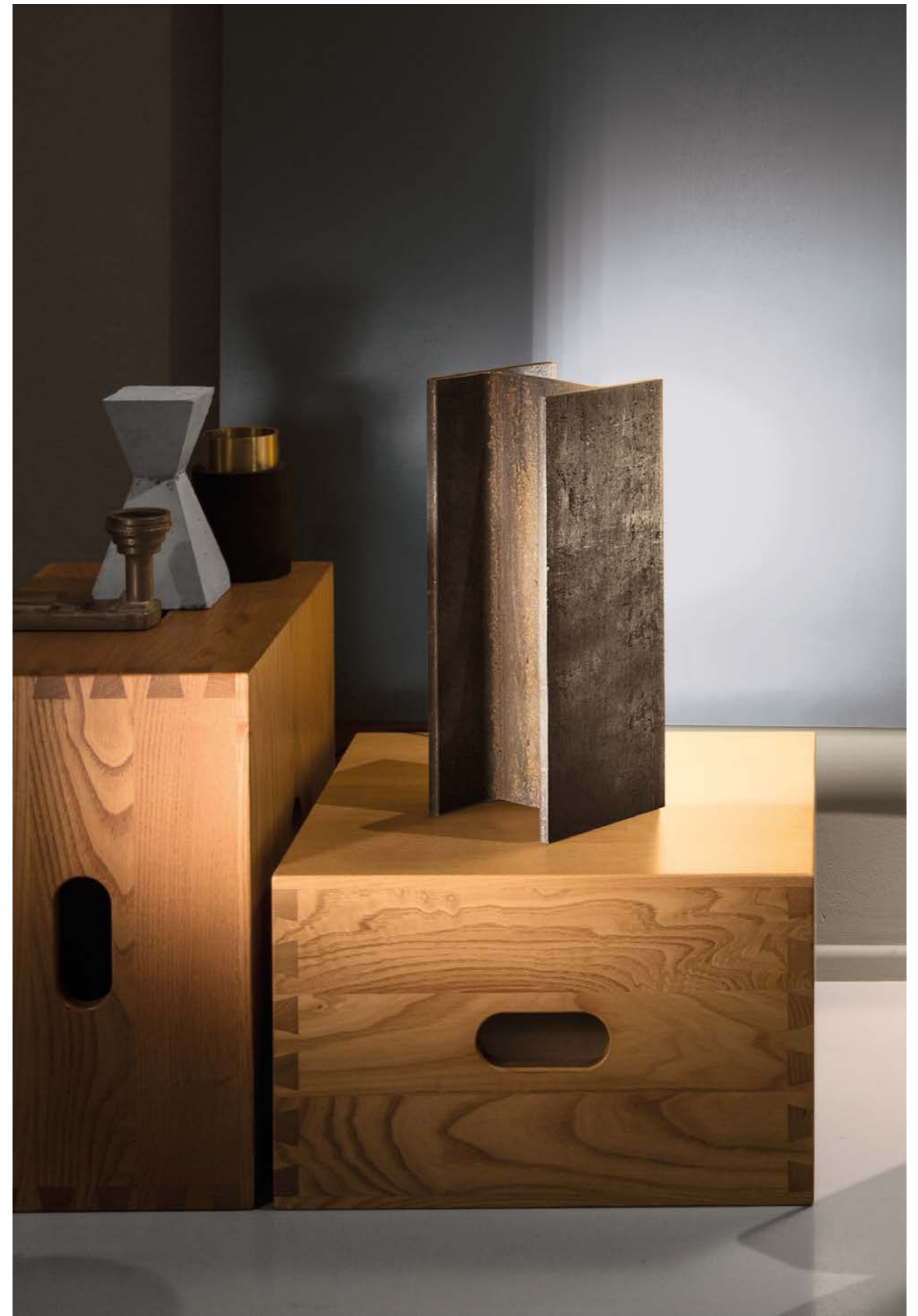

# KEPLER

*Arihiro Miyake*



*Kepler uplight, white finishing.*

Kepler downlight, black finishing.  
NEXT PAGE: Kepler downlight, white finishing.

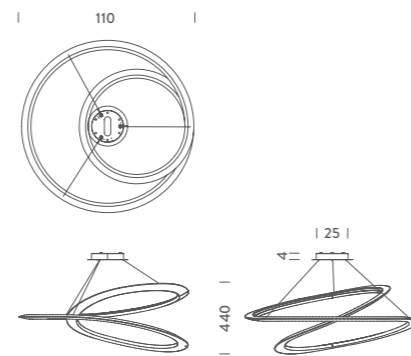

Pendant lamp in epoxy-coated aluminium. Available in the uplight and downlight versions, in matt white or black, for a widespread and comfortable lighting. The endless line is made through a 3 dimensional deformation process of the extruded aluminium, designed with the arithmetic of the Moebius ribbons.

Lampada a sospensione in alluminio verniciata a polvere. Disponibile nelle versioni up e down in bianco o nero opaco per un'illuminazione diffusa e confortevole. La linea continua è realizzata attraverso un processo di lavorazione tridimensionale dell'estruso di alluminio, disegnata sulla base del principio geometrico del nastro di Moebius.

Suspension en aluminium vernis epoxy. Disponible dans les versions up et down en blanc ou noir mat. Lumière diffuse et confortable. La ligne continue est réalisée grâce à un procédé d'élaboration tridimensionnelle d'extrusion d'aluminium, dessinée sur la base du principe géométrique du ruban de Möbius.

Pendelleuchte aus pulverlackiertem Aluminium, matt weiß oder matt schwarz, lieferbar als Up- und Down-Light für eine diffuse und angenehme Beleuchtung. Die endlose Linie, die auf der Grundlage des geometrischen Prinzips des Möbiusbands entworfen wurde, wird durch einen dreidimensionalen Bearbeitungsvorgang des extrudierten Aluminiums realisiert.

#### UPLIGHT

Linear LED | indirect | 60W | 6000lm | typ cri 83 |  
CCT 3000K | dimmable 1-10V | 110/240V  
note cable length 2,5m

- KEP LWW 51 structure white
- KEP LNN 51 structure black

#### DOWNLIGHT

Linear LED | indirect | 60W | 6000lm | typ cri 83 |  
CCT 3000K | dimmable 1-10V | 110/240V  
note cable length 2,5m

- KEP LWW 52 structure white
- KEP LNN 52 structure black





# PROJECTEUR 365 IP54

*Le Corbusier 1954*





The Projecteur IP54, available in wall/ceiling and pendant version, was designed by Le Corbusier for the Chandigarh High Court, India, in 1954. Aluminium body painted in night blue, white sand or moka. Diffuser glass curved and sandblasted in the inner part. Painted body, base and canopies. Screws and small metal parts black chromed.

Il Projecteur IP54, disponibile nelle versioni parete/soffitto e sospensione, è stato disegnato da Le Corbusier per illuminare l'Alta Corte di Chandigarh, India, nel 1954. Il corpo della lampada è in alluminio verniciato blu notte, bianco sabbia o moka. Il vetro diffusore è bombato e sabbiato internamente. La base e i rosconi sono verniciati come il corpo. I galletti di chiusura sono cromati neri come il resto della minuteria.

Le Projecteur IP54, disponible en version applique/plafonnier et suspension, a été dessiné par Le Corbusier pour éclairer l'Alta Corte de Chandigarh, India, en 1954. Le corps de la lampe est en aluminium vernis bleu nuit, blanc sable ou moka. Le verre diffusant est bombé et sablé à l'intérieur. La base et les patères sont vernies comme le corps. Les vis papillons de fermeture sont chromées noires comme le reste de la visserie.

Der Projecteur IP54, lieferbar als Wand/Decken- und Pendelleuchte wurde 1954 von Le Corbusier für die Beleuchtung des Gerichtshofes in Corte di Chandigarh in Indien entworfen. Der Leuchtenkörper ist aus Aluminium; nachtblau, sand- oder mokafarben lackiert. Das gewölbte Diffusorglas ist innen sandgestrahlt. Die Basen und Baldachine sind in der Farbe der Leuchtenkörper lackiert. Die Flügelmuttern und Kleinteile sind matt schwarz verchromt.

#### PENDANT IP 54

E27 bulb | direct | 100W |  
dimnable, according to the bulb | 230V  
note cable lenght 3m

- PRJ EDW 5E *structure night blue*
- PRJ EWS 5E *structure white sand*
- PRJ EMS 5E *structure moka*

#### WALL/CEILING IP 54

E27 bulb | direct | 100W |  
dimnable, according to the bulb | 230V  
note orientable

- PRJ EDW 3E *structure night blue*
- PRJ EWS 3E *structure white sand*
- PRJ EMS 3E *structure moka*

*Projecteur 365 wall IP 54 white sand.*  
NEXT PAGE: *Projecteur 365 wall IP 54 night blue.*

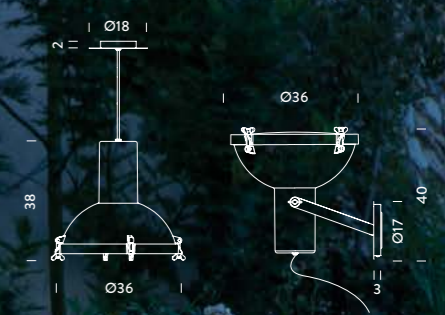

# 3TUBES

Charles Kalpakian



*3Tubes white and white/copper finishing.*

Aluminium pendant lamp for a warm diffused illumination on the surface.  
Diffusers in opal polycarbonate. Available in white or white and anodized copper finish.

Lampada a sospensione in alluminio per un'illuminazione omogenea, calda e diffusa sul piano.  
Diffusori in policarbonato opaco. Disponibile nella finitura bianca o bianca e rame anodizzato.

Suspension en aluminium pour un éclairage homogène, chaud et diffuse sur le plan.  
Diffuseurs en polycarbonate opale. Disponible en blanc ou blanc/cuivre anodisé

Pendelleuchte in Aluminium für eine warme homogene Beleuchtung.  
Diffusoren aus opalen Polykarbonat. Lieferbar in weiß, schwarz oder kupfer eloxiert.

## PENDANT LED

LED | 14,5W | CCT 2700K | 1500lm | typ cri 80 |  
dimnable, TRIAC | 230V  
note cable lenght 3m

- TTB LWC 51 structure white/copper
- TTB LWW 51 structure white

# BORNE BÉTON

*Le Corbusier 1952*





Concrete outdoor and indoor floor and table lamp, conceived for the Unité d'habitation de Marseille and for Bhakra Dam, Sukhna Dam in India in 1952.

Lampada da terra e da tavolo in cemento, disponibile per interno ed esterno, realizzata per il progetto Unité d'Habitation de Marseille e per Bhakra Dam, Sukhna Dam in India nel 1952.

Lampe au sol et table en ciment, disponible pour intérieur et extérieur, réalisée pour le Projet Unité d'Habitation de Marseille et pour Bhakra Dam, Sukhna Dam en Inde en 1952.

Steh- und Tischleuchte aus Zement, lieferbar in den Versionen In- und Outdoor. Diese Leuchte wurde für das Projekt Unité d'Habitation de Marseille/Bhakra Dam, Sukhna Dam entworfen.



#### PETITE LED OUTDOOR IP65

LED board | direct | 19,2W | 1900lm | typ cri 80 | CCT 3000K | 110-230 | note cable lenght 3m, cable supplied with molded IP44 plug

● BBP LDW 22 structure concrete

#### PETITE LED INDOOR

LED board | direct | 19,2W | 1900lm | typ cri 80 | CCT 3000K | dimmable | 110-230V | note cable lenght 2,7m, dimmer on cable

● BBP LDW 21 structure concrete

#### PETITE HALO INDOOR

HALO R7s | direct | 250W | dimmable | 230V | note cable lenght 2,7m, dimmer on cable

● BBP HDD 21 structure concrete

#### GRANDE LED OUTDOOR IP65

LED board | direct | 38,4W | 3800lm | typ cri 80 | CCT 3000K | 110-230V | note cable lenght 3m, cable supplied with molded IP44 plug

● BBG LDW 21 structure concrete

#### GRANDE LED INDOOR

LED board | direct | 38,4W | 3800lm | typ cri 80 | CCT 3000K | dimmable | 110-230V | note cable lenght 2,7m, dimmer on cable

● BBG LDW 22 structure concrete

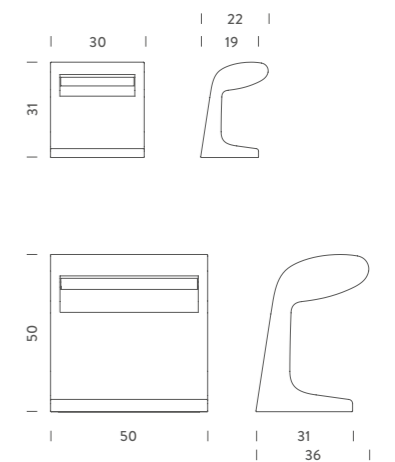

Borne Béton Grande outdoor.



*Borne Béton Petite indoor.*

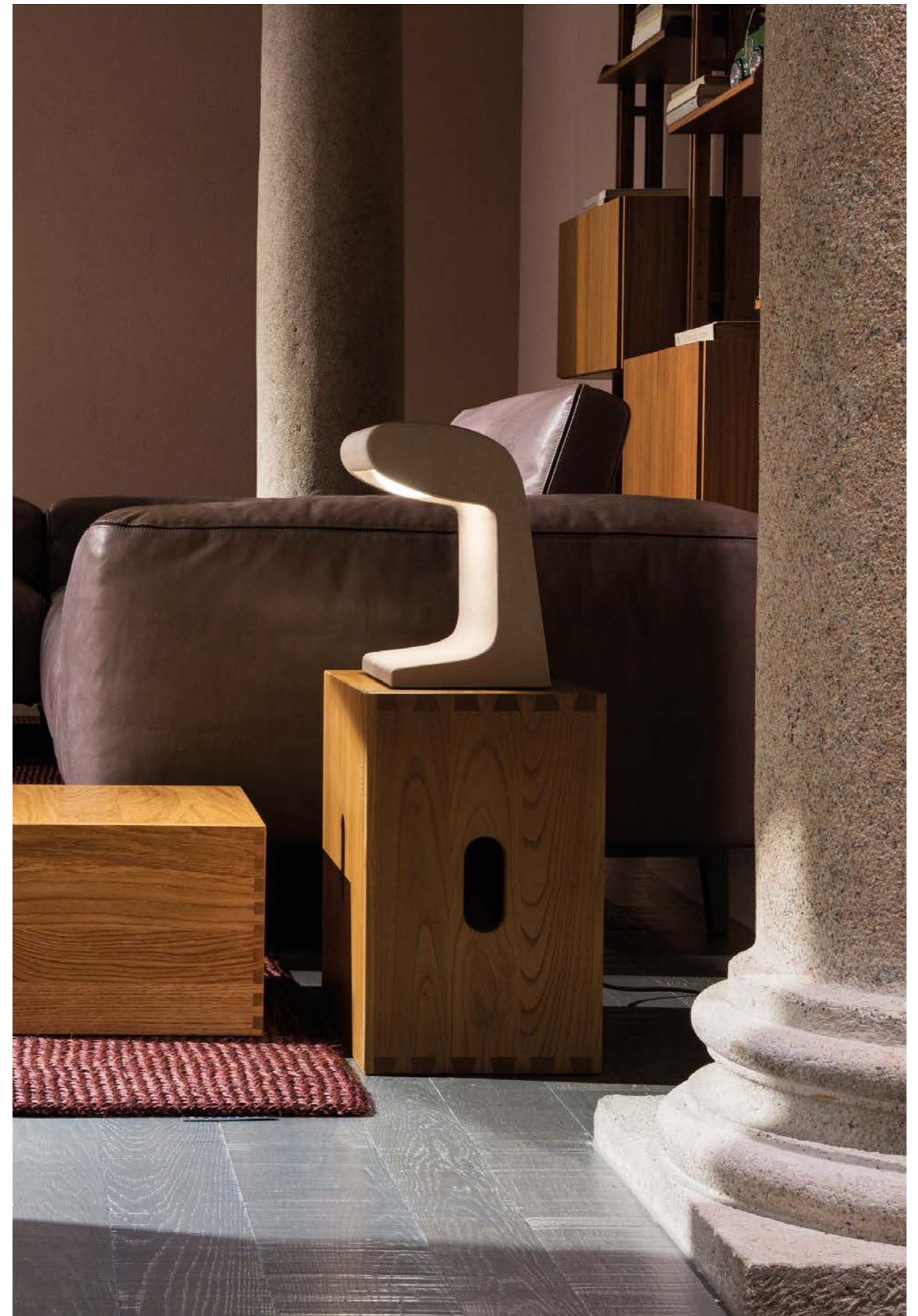

# LINESCAPES SYSTEM

*Nemo Studio*

Linescapes is a modular system that is changing completely the approach to highly performance diffused direct and indirect lighting. The singular modules are connected by quick moulded ABS connectors, which enable rapid jack installation and a 360° rotation. The different elements allow the composition of continuous lines and edges, with a luminous efficiency and an excellent diffusion degree, through an opaline diffuser in polycarbonate. The system has been studied to provide user friendly maintenance. Nemo has solved in an efficient way the problem of replacing LED built-in sources, whereby the single lighting elements can be easily changed.

Linescapes è un sistema modulare che cambia completamente l'approccio all'illuminazione diretta ed indiretta altamente performante. I singoli moduli sono uniti da snodi plastici in ABS stampati che permettono una rapida installazione jack ed una rotazione a 360°. I vari elementi permettono la composizione di linee continue ed angoli, con un'efficienza luminosa ed un eccellente grado di diffusione attraverso un diffusore opalino in policarbonato. Il sistema è stato studiato per permettere una manutenzione semplice. Nemo ha risolto in modo efficace la sostituzione dei LED, per cui i singoli elementi possono essere facilmente cambiati.

Linescapes est un système modulaire qui modifie intégralement le concept de l'éclairage direct et indirecte de haute performance. Les modules simples sont unis par des articulations jacks en plastique moulé ABS qui permettent une installation rapide et une rotation a 360°. Les différents éléments permettent la composition de lignes continues et d'angles, avec une efficacité lumineuse et un excellent niveau de diffusion, grâce à un diffuseur en polycarbonate opal. Le système a été étudié pour une manutention simple. Nemo a résolu de façon efficace le problème du changement des Leds, les éléments peuvent être facilement substitués.

Linescapes ist ein leistungsstarkes modulares System, das eine komplett neue Ansatzweise der direkten und indirekten Beleuchtung bietet. Die einzelnen Module sind durch Gelenke verbunden, die eine schnelle Jack-Installation und eine 360°Drehbarkeit ermöglichen. Die verschiedenen Elemente erlauben Kompositionen von fortlaufenden Linien und Ecken, mit einer hohen Lichtausbeute und einer hervorragenden Lichtstreuung durch einen Diffusor aus opalem Polycarbonat. Bei der Entwicklung dieses Systems wurde auf eine einfache Handhabung geachtet. Nemo hat das Auswechseln der LED's effizient gelöst, die einzelnen Elemente können ganz einfach ausgetauscht werden.

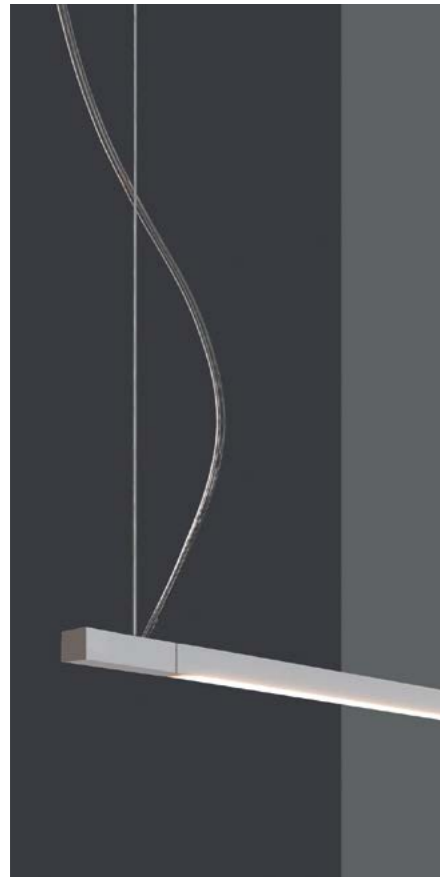

Horizontal start.

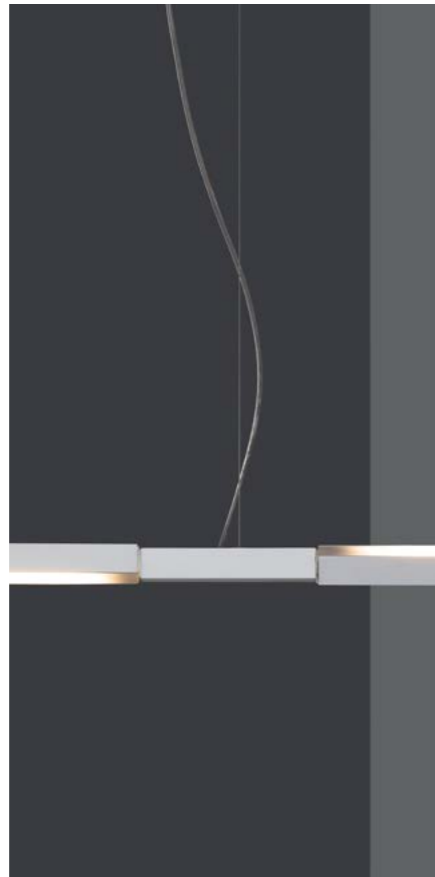

Central supply.



Down vertical angle and up vertical angle.



Down vertical angle and up vertical angle.

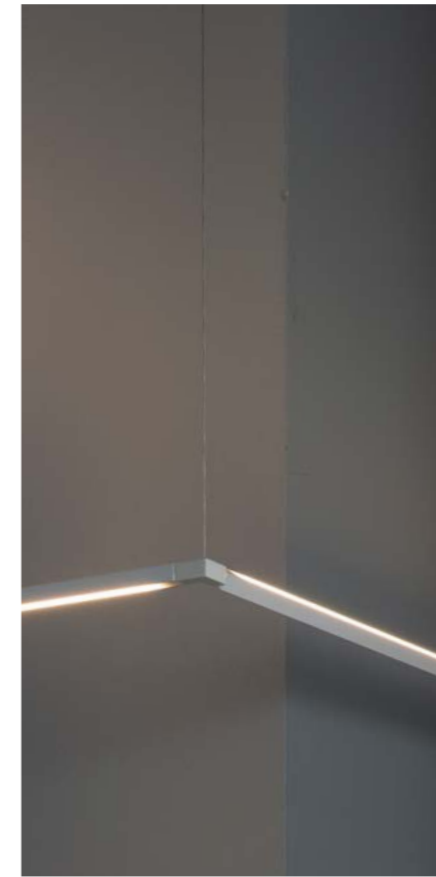

Horizontal angle.

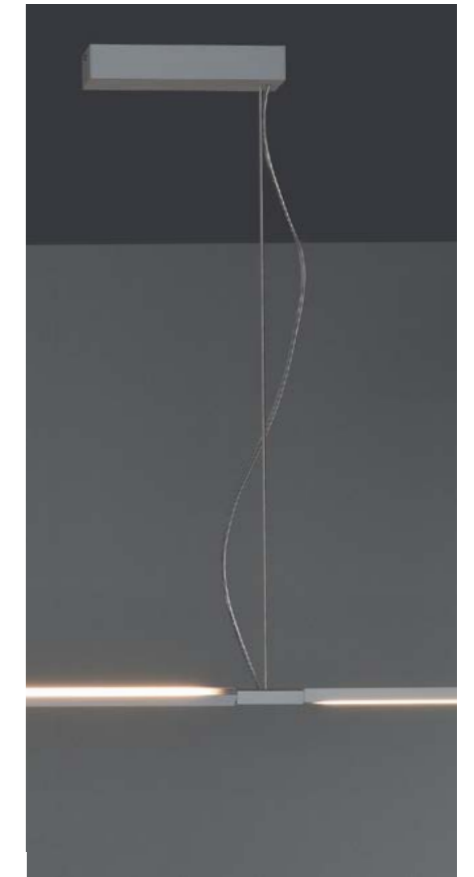

Central supply and 60W power supply.

## LIGHTING BARS

170 cm

Linear LED | diffused orientable | 40W  
typ cri 80 | CCT 3000K | 3960lm | 24V DC

● LSS LN1 511 black ○ LSS LW1 511 white

106 cm

Linear LED | diffused orientable | 24W  
typ cri 80 | CCT 3000K | 2400lm | 24V DC

● LSS LN2 511 black ○ LSS LW2 511 white

56 cm

Linear LED | diffused orientable | 12W  
typ cri 80 | CCT 3000K | 1200 lm | 24VDC

● LSS LN3 511 black ○ LSS LN2 511 white

36 cm

Linear LED | diffused orientable | 7W  
typ cri 80 | CCT 3000K | 700lm | 24 VDC

● LSS LN4 511 black ○ LSS LW4 511 white

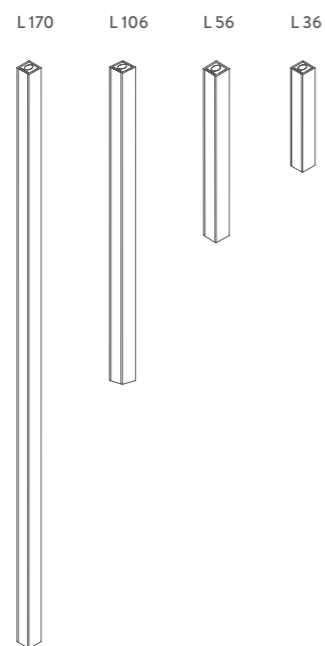

## CONNECTIONS

### VERTICAL START

● LSS CN1 511 black ○ LSS CW1 511 white

### HORIZONTAL START

● LSS CN2 511 black ○ LSS CW2 511 white

### HORIZONTAL END

● LSS CN3 511 black ○ LSS CW3 511 white

### CENTRAL SUPPLY

● LSS CN4 511 black ○ LSS CW4 511 white

### CENTRAL

● LSS CN5 511 black ○ LSS CW5 511 white

### UP VERTICAL ANGLE

● LSS AN1 511 black ○ LSS AW1 511 white

### DOWN VERTICAL ANGLE

● LSS AN2 511 black ○ LSS AW2 511 white

### HORIZONTAL ANGLE

● LSS AN3 511 black ○ LSS AW3 511 white

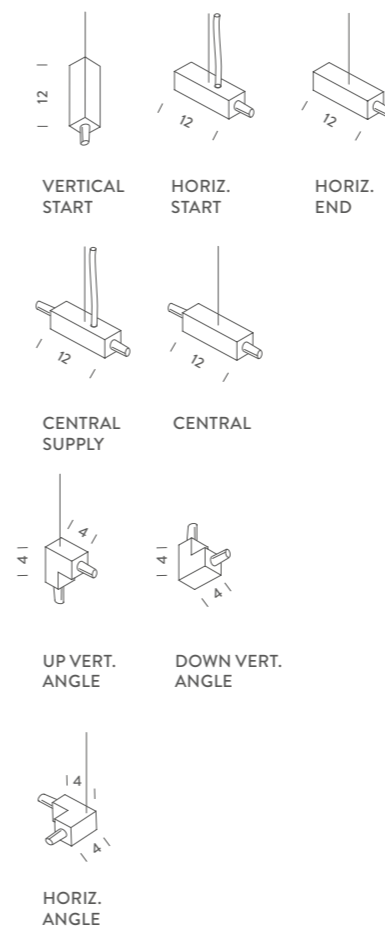

## POWER SUPPLIES

### 60W 1-10V

● LSS PN6 511 black ○ LSS PW6 511 white

### 90W 1-10V

● LSS PN9 511 black ○ LSS PW9 511 white

*note:* additional drivers available on the basis of a specific project.

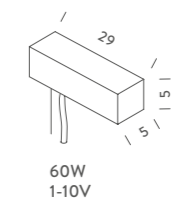

60W 1-10V

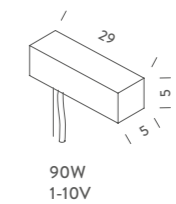

90W 1-10V

## ACCESSORIES

### CEILING PLATE for recessed ceiling application

● LSS PNR 511 black ○ LSS PWR 511 white

*note:* driver not included

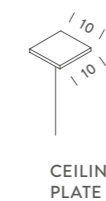

CEILING PLATE





# OLYMPIA

*Doriana e Massimiliano Fuksas*



Adjustable wall lamp with moulded diffuser in semi-transparent polycarbonate, for a widespread lighting. Stem in black painted aluminium, ABS wall plate.

Lampada orientabile da parete con diffusore stampato in policarbonato semi-trasparente, per un'illuminazione diffusa. Stelo in alluminio verniciato nero, staffa a parete in ABS.

Applique orientable avec diffuseur moulé en polycarbonate semi-transparent, pour un éclairage diffus. Structure en aluminium vernis noir, patène en ABS.

Verstellbare Wandleuchte, Diffusor aus halbdurchsichtigem Polykarbonat für eine diffuse Lichtstreuung. Arm aus schwarz lackiertem Aluminium, Wandhalterung aus ABS.

LED | diffused, 360° | 12W | CCT 3000K | 1300lm  
dimnable, TRIAC | 220V  
note cable lenght 280cm, dimmer on cable

● OLY LNN 31 structure black

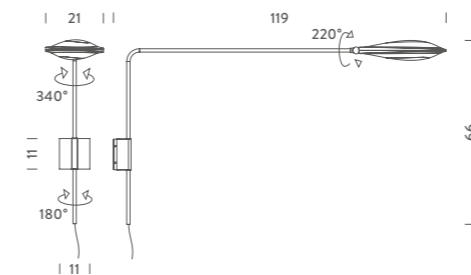

# TRU PENDANT

*Roberto Paoli*



*Tru Pendant, up+downlight, black finishing.*

Horizontal and vertical pendant lamp with double linear LED source. Body in extruded aluminium. Heads in polymeric material, with diffusers in opal metacrylate. Structure painted in matt white or black. Horizontal version available with uplight and downlight flood, or total up and total down. Dimmable.

Lampada a sospensione orizzontale e verticale con doppia sorgente lineare LED. Corpo in alluminio estruso, testate realizzate in materiale polimerico con diffusori in metacrilato opalino. La struttura è verniciata bianco opaco o nero. Versione orizzontale disponibile nella versione con luce uplight e downlight, oppure total up e total down. Dimmerabile.

Suspension horizontale et verticale à double source LED. Corps en aluminium extrudé, la partie supérieure et la base sont en matériau polymère, diffuseurs en méthacrylate opalin. Structure en blanc ou noir mat. Version horizontale disponible avec émission uplight/downlight ou total uplight ou total downlight. Dimmable sur le câble.

Horizontale und vertikale Pendelleuchte mit doppeltem LED-Strip. Struktur aus fließgepresstem Aluminium. Kopfstücke aus Polymermaterial. Diffusoren aus opalweißem Methacrylat. Die Struktur ist matt weiß oder schwarz lackiert. Lieferbar als Up- und Down-Light, total Down oder total Up. Dimmbar.

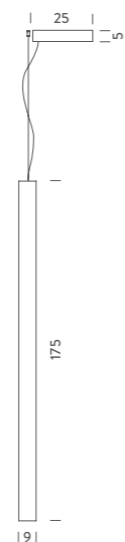

#### PENDANT UP+DOWN

Linear LED | up+down | 2x41W | typ cri 83 | 3000K | 4080lm | dimmable 1-10V | 110/230V  
note cable length 3m

- TRU LWW 51 structure white
- TRU LNN 51 structure black

#### PENDANT UP+UP

Linear LED | up+up | 2x41W | typ cri 83 | 3000K | 4080lm | dimmable 1-10V | 110/230V  
note cable length 3m

- TRU LWW 52 structure white
- TRU LNN 52 structure black

#### PENDANT DOWN+DOWN

Linear LED | down+down | 2x41W | typ cri 83 | 3000K | 4080lm | dimmable 1-10V | 110/230V  
note cable length 3m

- TRU LWW 53 structure white
- TRU LNN 53 structure black

#### PENDANT VERTICAL

Linear LED | 41W | typ cri 83 | 3000K | 4080lm  
dimmable 1-10V | 110/230V  
note cable length 3m

- TRU LWW 54 structure white
- TRU LNN 54 structure black

Tru Pendant Vertical black finishing.  
NEXT PAGE: Tru Pendant Horizontal  
up+downlight, black finishing.

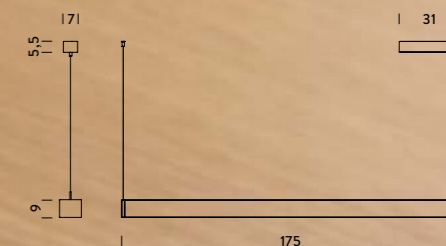
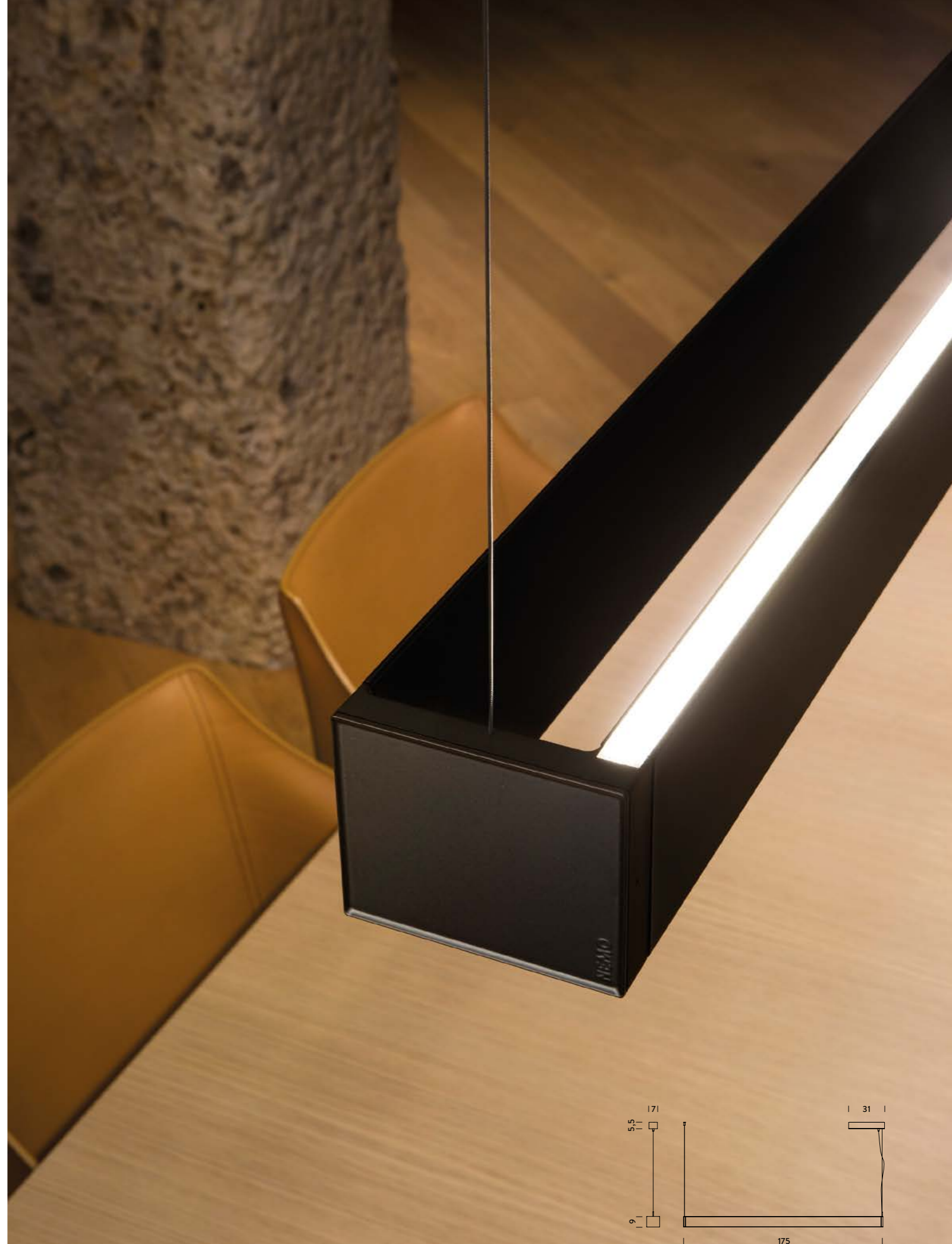

# PARLIAMENT

*Le Corbusier 1963*

Le Corbusier conceived the lamp Parliament for the Chandigarh Parliament in India. Floor lamp, double adjustable emission, in painted aluminium with diffusers matt black and yellow or white and grey. Whitewash internal diffusers. Stem matt grey.

Parliament è stata progettata da Le Corbusier per il Chandigarh Parliament in India. È una lampada da terra orientabile a doppia emissione, in alluminio verniciato con diffusori nero opaco e giallo o bianco e grigio. Diffusori interni in bianco calce. Asta in grigio opaco.

Parliament a été conçu par Le Corbusier pour La Haute Cour de Chandigarh, Inde. Lampadaire orientable à double émission, en aluminium laqué avec diffuseurs noir mat et jaune ou blanc et gris. L'intérieur des diffuseurs chaux blanche. Tige gris mat.

Die Parliament wurde von Le Corbusier für das Chandigarh Parliament in Indien entworfen. Stehleuchte orientierbar und mit doppeltem Lichtaustritt, aus lackiertem Aluminium mit Diffusoren in matt schwarz und gelb oder weiß und grau, innen kalbweiß, Schaft in matt grau.

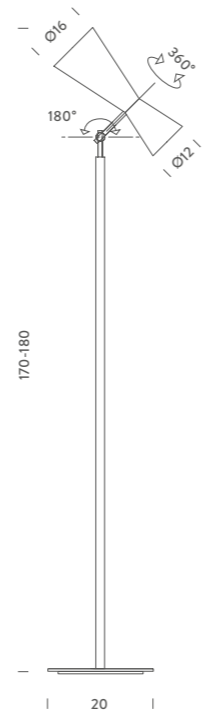

E27 FLUO/LED/HALO

E27, A60 | double, direct+indirect | 2x52W  
dimnable | 230V  
note cable length 2,7m, dimmer on cable

○ PAR EDW 21 structure whitewash/grey  
● PAR ENG 21 structure black / yellow



# SPIGOLO XS

Studiocharlie



Table lamp, in aluminium. Polycarbonate ABS joints and opal metacrylate diffusers that can rotate 360°.

Lampada da tavolo, realizzata in alluminio. Giunti stampati in policarbonato e diffusori in metacrilato opalino. I diffusori sono orientabili di 360°.

Lampe de table en aluminium. Raccords en plastique moulés ABS et diffuseurs en métacrylate opalin, qui tournent à 360°.

Tischleuchte aus Aluminium. Verbindungsstücke aus Polykarbonat ABS, Diffusoren aus opalem Methacrylat, drehbar bis 360°.

## TABLE, INDOOR

Linear LED | diffused, 360° | 7,2W  
720lm | typ cri 80 | CCT 2700K | 110/240V  
*note cable lenght 2m, switch on cable*

- SPI LWW 11 *structure white*
- SPI LNN 11 *structure black*

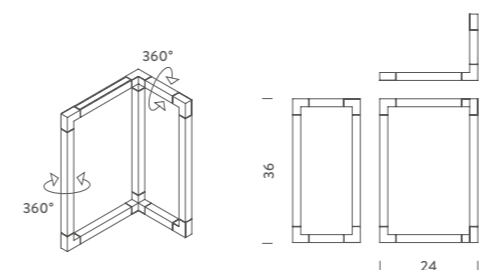

# ELLISSE

*Federico Palazzari*



LED pendant lamp, available in three versions: major, minor and double, widespread direct or indirect lighting. Extruded aluminium, matt white, matt black painted, polished or glossy gold anodization. Opaline diffuser. Ellisse is manufactured through a technology studied by NEMO to combine the extruded bar (patent pending).

Lampada a sospensione LED in tre versioni: major, minor e double, per luce diffusa diretta o indiretta, in estruso di alluminio verniciato bianco opaco, nero opaco, spazzolato o anodizzato oro lucido. Diffusore opalino. Ellisse è realizzata attraverso una tecnologia di accoppiamento dell'estruso sviluppata da NEMO (patent pending).

Lampe à suspension LED en trois versions: major, minor et double, pour une lumière diffuse directe ou indirecte, en aluminium extrudé verni blanc, noir mat, poli ou poli or. Diffuseur opalin. Ellisse est réalisée grâce à une technique de couplage de l'extrudé, étudiée par NEMO (brevet en cours).

LED-Pendelleuchte in drei Versionen: minor, major und double mit einer diffusen indirekten oder direkten Lichtausstrahlung, aus Aluminium, lieferbar in den Ausführungen matt weiß oder matt schwarz lackiert, poliert oder goldglänzend. Opaler Diffusor. Ellisse wurde mit einer von NEMO entwickelten Extrusionsverbindungstechnik realisiert (patent pending).

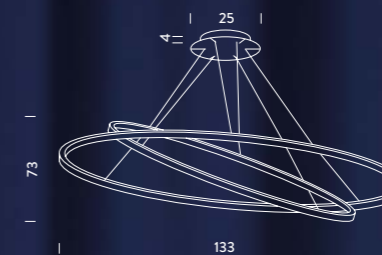

## PENDANT DOUBLE LED

Linear LED | diffused uplight (minor),  
diffused downlight (major) | 90W |  
5400+3900lm | typ cri 80 | CCT 3000K |  
dimmable 1-10V | 110/230V  
*note cable lenght 2,5m*

- ELP LWW 56 *structure white*
- ELP LNW 56 *structure black*
- ELP LGW 56 *structure gold polished anodization*
- ELP LLW 56 *structure polished aluminium*

*Ellisse Double, white finishing.*

## PENDANT MAJOR, LED

Linear LED | diffused orientable | 78W  
typ cri 80 | CCT 3000K | 7800lm  
dimmmable 1-10V | 110/230V  
note cable lenght 2,5m

### uplight

- ELP LWW 53 structure white
- ELP LNW 53 structure black
- ELP LGW 53 structure gold polished anodization
- ELP LLW 53 structure polished aluminium

### downlight

- ELP LWW 54 structure white
- ELP LNW 54 structure black
- ELP LGW 54 structure gold polished anodization
- ELP LLW 54 structure polished aluminium

## PENDANT MINOR, LED

Linear LED | diffused orientable | 54W  
typ cri 80 | CCT 3000K | 5400lm  
dimmmable 1-10V | 110/230V  
note cable lenght 2,5m

### uplight

- ELP LWW 51 structure white
- ELP LNW 51 structure black
- ELP LGW 51 structure gold polished anodization
- ELP LLW 51 structure polished aluminium

### downlight

- ELP LWW 52 structure white
- ELP LNW 52 structure black
- ELP LGW 52 structure gold polished anodization
- ELP LLW 52 structure polished aluminium

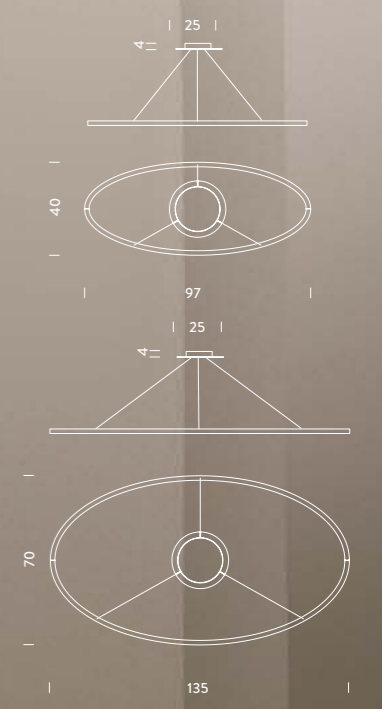

*Ellisse Major Uplight gold plated and polished aluminium finishing.*



# CROWN WALL

Jehs+Laub



Wall lamps, with modular structure in die-casted aluminium and sandblasted glass diffusers. Structure in aluminium hand polished glossy or gold plated or painted in matt white, matt black or gold.

Lampade da parete, realizzate con una struttura modulare in alluminio pressofuso e bicchierini diffusori in vetro sabbato. La struttura è disponibile in versione alluminio spazzolato lucido, dorato oppure verniciato opaco nei colori bianco, nero o oro.

Applique, réalisée avec une structure modulaire en aluminium moulé. Diffuseurs en verre sablé. Disponible en aluminium poli à la main, brillant ou or, ou peint en blanc mat, noir mat ou doré.

Wandleuchten mit einer modularen Struktur aus Aluminiumdruckguß und sandgestrahlten Diffusorgläsern. Die Struktur ist glänzend poliert, vergoldet oder in matt weiß, matt schwarz und goldfarben lackiert lieferbar.

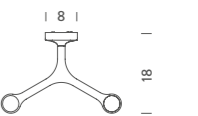
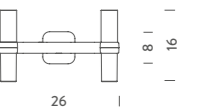
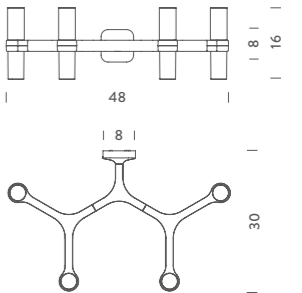

## CROWN WALL 2 HALO/LED

Halopin G9 QT-14 | diffused | 2x60W  
dimnable | 110/230V  
*note* LED version with kit g9 led Nemo

- CRO HWW 31 *structure* white
- CRO HLW 31 *structure* polished
- CRO HNW 31 *structure* black
- CRO HGW 31 *structure* gold
- CRO HOW 31 *structure* gold plated

## CROWN WALL 4 HALO/LED

Halopin G9 QT-14 | diffused | 4x60W  
dimnable | 110/230V  
*note* LED version with kit g9 led Nemo

- CRO HWW 32 *structure* white
- CRO HLW 32 *structure* polished
- CRO HNW 32 *structure* black
- CRO HGW 32 *structure* gold
- CRO HOW 32 *structure* gold plated

*Crown wall 4, gold paint finishing.  
PREVIOUS PAGE: Crown wall 2, polished.*

*Art direction  
and graphic design*

Valentina Folli

*Photos*

Cube Photo Production  
Alexander Böhle

*Furniture by*

Cappellini  
Cassina  
Magis

*Special thanks*

Cappellini Point Milano  
Cassina Showroom Milano  
HDH House Design Holiday

*Stampa*

Stamperia Scrl

*This document supersedes and  
updates all previous catalogues and  
publications in relation to the  
products listed here in.*

*Questa pubblicazione sostituisce ed  
aggiorna i precedenti cataloghi con  
riferimento ai prodotti elencati.*

*[www.nemolighting.com](http://www.nemolighting.com)*

NEMO products are designed and manufactured in compliance with EN 60598-1 norms.

Dimensions are indicated in centimetres.

Supply voltage can be either 230V, 50Hz.

Luminaires are normally supplied without light sources, except when otherwise indicated in the price list.

Characteristics of the light sources are indicated in the specifications of each appliance.

Products with anodized finishes could show different colour shades due to the industrial galvanic process. Shades have to be considered as aesthetic elements of the product. Polishing process is hand-made. Shades are therefore due to this manual process.

Dimensions of products made with deformations of extrusions could be subject to changes of  $\pm 1$ cm.

As blown glass is produced by traditional craft techniques, its thickness, colour and finish are subject to variations, a feature that makes each piece unique.

NEMO reserves the right to make any technical or formal alterations to its products without giving prior notice, especially for LED sources.

The value "lighting output" it refers to the nominal flux of the LED source.

For photometric data, please refer to the website.

Warranty conditions are indicated in a tag attached to each luminaire.

**Architecture is the  
learned game, correct  
and magnificent, of  
FORMS ASSEMBLED  
IN THE LIGHT.**

Le Corbusier<sup>®</sup>